

European Solar Energy Storage

Risk assessment plan for mobile energy storage industry



IP65/IP55 OUTDOOR CABINET

ALUMINUM

OUTDOOR ENERGY STORAGE CABINET

OUTDOOR EQUIPMENT CABINET



Overview

Stationary energy storage can bring with it risk management concerns and increase challenges associated with ensuring public safety. There is no expectation that the rapid evolution of stationary storage associated with energy storage technologies will slow as the costs continue to fall, new.

Stationary energy storage can bring with it risk management concerns and increase challenges associated with ensuring public safety. There is no expectation that the rapid evolution of stationary storage associated with energy storage technologies will slow as the costs continue to fall, new.

This work describes an improved risk assessment approach for analyzing safety designs in the battery energy storage system incorporated in large-scale solar to improve accident prevention and mitigation, via incorporating probabilistic event tree and systems theoretic analysis. The causal factors.

Apart from Li-ion battery chemistry, there are several potential chemistries that can be used for stationary grid energy storage applications. A discussion on the chemistry and potential risks will be provided. Challenges for any large energy storage system installation, use and maintenance include.

That's exactly why understanding the risk assessment of the mobile energy storage industry isn't just important - it's survival 101 in this rapidly evolving sector. This piece is gold for: We're serving up hard data, real-world horror stories, and actionable solutions - no fluff allowed. 1.

This work describes an improved risk assessment approach for analyzing safety designs in the battery energy storage system incorporated in large-scale solar to improve accident prevention and mitigation, via incorporating probabilistic event tree and systems theoretic analysis. The causal factors. Can a large-scale solar battery energy storage system improve accident prevention and mitigation?

This work describes an improved risk assessment approach for analyzing safety designs in the battery energy storage system incorporated in large-scale solar to improve accident prevention and mitigation, via incorporating

probabilistic event tree and systems theoretic analysis. The causal factors and mitigation measures are presented.

Are grid-scale battery energy storage systems safe?

Despite widely known hazards and safety design of grid-scale battery energy storage systems, there is a lack of established risk management schemes and models as compared to the chemical, aviation, nuclear and the petroleum industry.

What is a risk assessment framework?

The causal factors and mitigation measures are presented. The risk assessment framework presented is expected to benefit the Energy Commission and Sustainable Energy Development Authority, and Department of Standards in determining safety engineering guidelines and protocols for future large-scale renewable energy projects.

Which risk assessment methods are inadequate in complex power systems?

Traditional risk assessment methods such as Event Tree Analysis, Fault Tree Analysis, Failure Modes and Effects Analysis, Hazards and Operability, and Systems Theoretic Process Analysis are becoming inadequate for designing accident prevention and mitigation measures in complex power systems.

What is a comprehensive review of energy storage systems?

A comprehensive review on energy storage systems: types, comparison, current scenario, applications, barriers, and potential solutions, policies, and future prospects. *Energies*, 13, 3651. International Electrotechnical Commission. (2020). IEC 62933-5-2:2020. Geneva: IEC. International renewable energy agency. (2050).

What are the dangers of electrical storage systems?

Energy storage systems with voltages above 50 V water can worsen the extent of the damage. Electrical arc enclosure (Zalosh et al., 2021). Arc flashes with incident national Electrotechnical Commission, 2020). During gency responders. toxic gases. High operating temperatures pose high risk s for human injuries and fires. Electrical hazards are pre

Risk assessment plan for mobile energy storage industry



Safety Challenges and Risk Analysis of Home Energy Storage ...

Risk Mitigation Measures for Energy Storage Systems (ESS) Safety issues are the red line of product quality, and ensuring the safety of energy storage systems has become ...

Energy Storage Safety Strategic Plan

Acknowledgements The Department of Energy Office of Electricity Delivery and Energy Reliability would like to acknowledge those who participated in the 2014 DOE OE Workshop for Grid ...

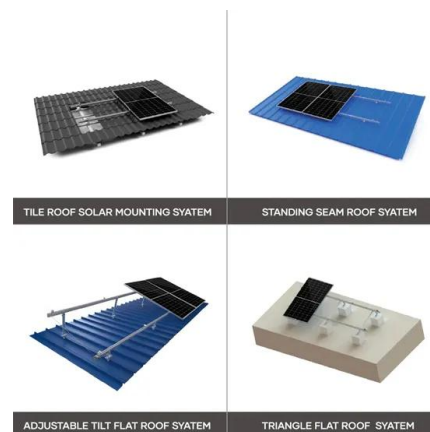

Guidance on the Safety of BESS on board ships

EMSA with the support of the European Commission, the Member States and the industry has drawn-up this non-mandatory Guidance to guide national administrations and industry, and ...



Application of Mobile Energy Storage for Enhancing Power ...

Compared to stationary batteries and other energy storage systems, their mobility provides operational flexibility to support geo-graphically dispersed loads across an outage area. This ...



Industrial chain risk assessment for the promotion of ...

The electrochemical energy storage industrial chain is extensive, spanning from upstream mining and battery material refining and processing, to midstream battery manufacturing and ...

Risk Assessment of the Mobile Energy Storage Industry: What ...

That's exactly why understanding the risk assessment of the mobile energy storage industry isn't just important - it's survival 101 in this rapidly evolving sector.

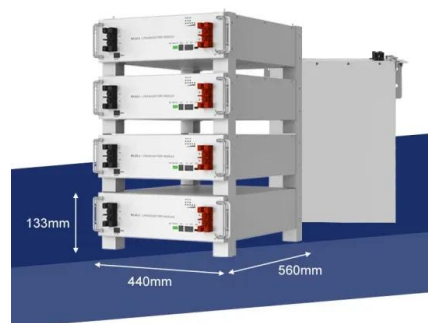

Energy Storage Safety Strategic Plan

The Department of Energy Office of Electricity Delivery and Energy Reliability Energy Storage Program would like to acknowledge the external advisory board that ...



Large-scale energy storage system: safety and risk assessment

The causal factors and mitigation measures are presented. The risk assessment framework presented is expected to benefit the Energy Commission and Sustain-able Energy ...



Grid-Scale Battery Energy Storage Systems - Construction

Introduction Grid-Scale Battery Energy Storage Systems (BESS) are a means of storing electrical energy, typically to provide grid services such as frequency regulation, peak shaving, voltage ...

Battery Energy Storage: Blueprint for Safety

A Framework for Action The battery energy storage industry has developed a comprehensive and proactive approach to ensuring safety across the United States. This Blueprint for Safety ...

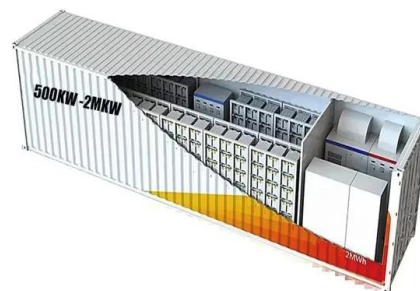

HANDBOOK FOR ENERGY STORAGE SYSTEMS

ABOUT THE ENERGY MARKET AUTHORITY The Energy Market Authority ("EMA") is a statutory board under the Ministry of Trade and Industry. Our main goals are to ensure a ...



Resilience assessment of power system considering mobile energy storage

To address the need for operational risk assessment and resilience improvement for power systems under extreme disasters, a resilience assessment method for power systems ...



Battery Energy Storage System (BESS) Training , BakerRisk

Battery Energy Storage System Hazards and Mitigation Course This two-half day course is intended to give participants an overview of the Lithium-ion battery components, primary failure ...



Large-scale energy storage system: safety and risk assessment

The risk assessment framework presented is expected to benefit the Energy Commission and Sustainable Energy Development Authority, and Department of Standards in determining ...



Creating a Risk Assessment Culture for State Energy ...

Methods and Tools for Assessing Risk Many approaches have been developed to analyze components of risk related to energy infrastructure. Private industry, trade and research ...

RISK MITIGATION APPROACH GUIDEBOOK FOR STATE ...

The Risk Mitigation Guidebook for State Energy Security Plans was developed by DOE CESER with funding from the DOE's State Energy Program in the Office and State and Community ...



- IP65/IP55 OUTDOOR CABINET
- ALUMINUM
- OUTDOOR ENERGY STORAGE CABINET
- OUTDOOR MODULE CABINET

Battery energy storage systems: key risk factors

As the energy crisis continues and the world transitions to a carbon-neutral future, battery energy storage systems (BESS) will play an increasingly important role. BESS can optimise wind & solar generation, ...

Battery Energy Storage Systems Report

This information was prepared as an account of work sponsored by an agency of the U.S. Government. Neither the U.S. Government nor any agency thereof, nor any of their employees, ...

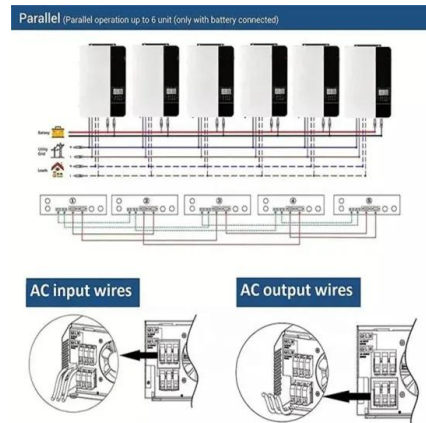

New CESER Report Offers Supply Chain Mitigation

Report Offers In-Depth Assessment of Battery Storage Supply Chain Risks and Proactive Mitigations for Industry Partners Office of Cybersecurity, Energy Security, and ...

Conducting a Risk Assessment for

Today's Discussion The Changing Environment Available Industry Risk Assessment Models Unique considerations when conducting a risk assessment for mobile devices Understanding ...



Energy Storage System Risk Assessment

This guide provides an in-depth look at the complexities of risk assessment for energy storage systems within the context of electric power generation, incorporating principles of Business ...



Battery Energy Storage System (BESS) Training

Battery Energy Storage System Hazards and Mitigation Course This two-half day course is intended to give participants an overview of the Lithium-ion battery components, primary failure modes of Battery Energy Storage ...



Emerging Renewable Energy Risks in 2025 , TÜV ...

The renewable energy sector is surging into 2025 with momentum, but as with any high-growth industry, new risks are emerging alongside opportunities. For risk managers, insurance carriers, and ...

Risk assessment and mitigation techniques for Renewable ...

o More comprehensive information and data on renewable energy technologies, coupled with industry education programmes, may enable development of expertise both within the ...



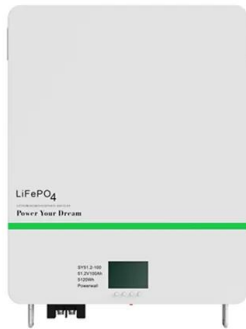

Managing Lithium Battery Risks: From Supply Chain to Storage

Lithium Battery Risks Lithium-ion batteries power essential devices across many sectors, but they come with significant safety risks. Risks increase during transport, handling, use, charging and ...

Energy Storage Safety Strategic Plan

pread deployment of energy storage. The second of these challenges, the validation of energy storage safety and reliability, has recently garnered significant attention from the energy ...

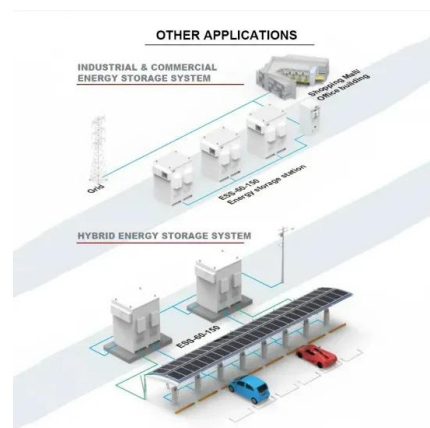

Large-scale energy storage system: safety and risk ...

This work describes an improved risk assessment approach for analyzing safety designs in the battery energy storage system incorporated in large-scale solar to improve accident prevention and ...

Mobile Energy Storage System Market Opportunities: Regional ...

The research report extensively segments the geographical overview of Mobile Energy Storage System Market industry The report comprises a detailed assessment of the ...



risk assessment plan for mobile energy storage industry

This work describes an improved risk assessment approach for analyzing safety designs in the battery energy storage system incorporated in large-scale solar to improve accident prevention ...

BATTERY STORAGE FIRE SAFETY ROADMAP

The research topics identified in this roadmap should be addressed to increase battery energy storage system (BESS) safety and reliability. The roadmap processes the findings and lessons ...



Battery Energy Storage Systems (BESS) ...

Are BESS facilities safe The BESS industry is undergoing rapid growth and development. Lithium-ion batteries, commonly used in mobile phones and electric cars, are currently the dominant storage ...



Contact Us

For catalog requests, pricing, or partnerships, please visit:
<https://bialydom.kolobrzeg.pl>