

European Solar Energy Storage

Latvia microgrid design



Overview

What is a microgrid design tool?

The MDT allows designers to model, analyze, and optimize the size and composition of new microgrids or modifications to existing systems. Technology management, cost, performance, reliability, and resilience metrics are all offered by the tool.

What is a microgrid planning capability?

Planning capability that supports the ability to model and design new microgrid protection schemes that are more robust to changing conditions such as load types, inverter-based resources, and networked microgrids.

What is MDT - microgrid design toolkit?

MDT - Microgrid Design Toolkit (MDT) is a decision support tool developed by Sandia National Laboratories for microgrid designers to conduct microgrid design feasibility studies. The MDT allows designers to model, analyze, and optimize the size and composition of new microgrids or modifications to existing systems.

How can a microgrid controller be integrated with a distribution management system?

First, the microgrid controller can be integrated with the utility's distribution management system (DMS) directly in the form of centralized management. Second, the microgrid controller can be integrated indirectly using decentralized management via a Distributed Energy Resources Management System (DERMS).

How can microgrids improve the reliability of distribution and transmission systems?

One approach to producing this technology is to demonstrate how microgrids, especially networked microgrids, can help to improve the reliability of

distribution and transmission systems by providing them with reserves, i.e., capacity reserve, operational reserve, regulation reserve, etc.

Should microgrid planning and design tools be repurposed?

While microgrid planning and design tools achieve their project goals and requirements, repurposing them to meet new or evolving requirements is often a time consuming and difficult proposition.

Latvia microgrid design



latvia microgrid economics

In this paper, the microgrid economic scheduling mathematical model considering the integration of plug-in hybrid electric vehicles (PHEVs) is presented and the influence of different charging ...

Microgrid Engineering Conferences in Latvia 2024/2025/2026

Microgrid Engineering Conferences in Latvia 2024 2025 2026 is for the researchers, scientists, scholars, engineers, academic, scientific and university practitioners to present research ...

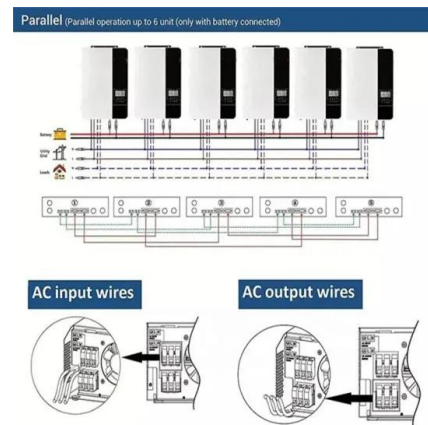

Microgrid Certificate: Planning, Design, and Implementation

Microgrid Certificate: Planning, Design, and Implementation is a 3-day hands-on workshop. Microgrid Planning, Design, and Implementation Training curriculum is a leading-edge certification and relevant to what is happening in the energy industry right now. A microgrid is a power generation system that is contained within a localized area that operates either independently ...

Fundamentals of Advanced

Microgrid Design , Archive

Advanced Microgrid Design Overview. We consider a "microgrid" to be an integrated energy system consisting of loads and generation operating as a coherent unit. Microgrids may operate either in parallel with, or islanded from, the main electric ...



Renewable Energy Solution , Wind Power Generation

Microgrid Design & Analysis. Microgrid Analysis & Design is an essential step for Microgrid Implementation. Upfront design and analysis of the target microgrid system, whether for brownfield or green-field Microgrid implementation, can help drive both technical and financial benefits, including determining optimized generation assets required to meet the microgrid ...

Renewable Energy Microgrid: Design and Simulation

The main objective of this project is to find a solution for the next problem: design a microgrid for a grid-connected, Zero-Energy Building, with a Low Voltage Direct Current (LVDC) distribution system, photovoltaic distributed generation, and a suitable storage system. 2.3. Scope In Scope: - Design the general scheme of the microgrid



Microgrid Design Framework

The challenge with microgrid design is that it can easily become a siloed process where customers, utilities and third-parties are not communicating well or at all. Microgrids are most successful

when utilities and third-parties work together to ...



Microgrid Design and Operation: Toward Smart Energy in Cities

With the growth of renewable energy sources, microgrids have become a key component in the distribution of power to localized areas while connected to the traditional grid or operating in a disconnected island mode. Based on the extensive real-world experience of the authors, this cutting-edge resource provides a basis for the design, installation, and day-by-day ...



BEST DESIGN LATVIA

2 ???· BEST DESIGN LATVIA showcases contemporary art, good design and great architecture from Latvia. Discover best designs from Latvia and the amazing designers, artists, and architects from Latvia behind the featured works. Discover inspirational Latvian designs, art and architecture.

Integrated Models and Tools for Microgrid Planning and ...

etc.; microgrids supporting local loads, to providing grid services and participating in markets. This white paper focuses on tools that

support design, planning and operation of microgrids (or aggregations of microgrids) for multiple needs and stakeholders (e.g., utilities, developers, aggregators, and campuses/installations).



Microgrid planning and design : a concise guide

Microgrid Planning and Design contains a review of microgrid benchmarks for the electric power system and covers the mathematical modeling that can be used during the microgrid design processes. The authors include real-world case studies, validated benchmark systems and the components needed to plan and design an effective microgrid system.

Microgrid Conceptual Design Guidebook , 2022 (Technical Report

The ultimate product resulting from the stepwise approach is a conceptual microgrid design. A conceptual design is defined as an initial design (10%-20% complete) that considers the specific threats, needs, limitations, and investment options for a given location. Going through this exercise and developing the conceptual microgrid design as a



Microgrids Design and Implementation

The micro grid concept has the potential to solve



major problems arising from large penetration of distributed generation in distribution systems. Microgrids Design and Implementation Antonio Carlos Zambroni de Souza Miguel Castilla Editors Microgrids Design and Implementation Editors Antonio Carlos Zambroni de Souza Institute of Electrical

Design , Microgrid Knowledge

The Microgrid Knowledge Design channel has breaking news and articles on microgrid designs. Concurrent Technologies Corporation. Kirtland AFB Awards New DC Microgrid Contract. June 7, 2023 . A first-of-its-kind Air Force system, the demonstration ...



Grid Deployment Office U.S. Department of Energy

Considering the typical microgrid design scenario of sizing generation to match peak load, Table 1 provides a rough sense of the power generation capacity required for a microgrid depending on the number and type of loads connected to the microgrid. Table 1. Rule-of-thumb generation capacity for possible loads served by a microgrid.

Microgrid Design and Operation: Toward Smart Energy in Cities

Based on the extensive real-world experience of the authors, this cutting-edge resource provides a basis for the design, installation, and day-by-day management of microgrids. Professionals ...



How to design microgrids and microgrid controls for small and ...

Many key market trends are driving faster adoption of microgrids and "microgrid-ready" facilities incorporating a variety of renewable energy resources like

[Sandia's Microgrid Design Toolkit](#)

The Microgrid Design Toolkit, developed by Sandia National Laboratories, provides decision support software for microgrid designers for use in the early stages of the design process. The MDT is the result of four years of investment by the Department of Energy Office of Electricity Delivery and Energy Reliability under the Smart Grid R& D program.



Optimized controllers design for incorporating renewable energy

2 ???· This paper presents the integration of renewable energy technologies in a DC microgrid, incorporating photovoltaic (PV) and battery systems connected to the grid. This paper focuses on strategies of maximum power

point tracking (MPPT) of PV system by using conventional and optimized controllers to provide reliable system of high quality electricity.

...



Design and operation of future low-voltage community ...

The utilization of artificial intelligence in the design and operation of a microgrid (MG) can contribute to improve its energy efficiency, resiliency, and cost of energy supply. This research ...



Microgrid Controller

ETAP Microgrid software allows for design, modeling, analysis, islanding detection, optimization and control of microgrids. ETAP Microgrid software includes a set of fundamental modeling tools, built-in analysis modules, and engineering device libraries that allow you to create, configure, customize, and manage your system model.



Microgrid Planning and Design: A Concise Guide , Wiley

A practical guide to microgrid systems architecture, design topologies, control strategies and integration approaches Microgrid Planning and Design offers a detailed and authoritative guide to microgrid systems. The authors - noted experts on the topic - explore what is involved in the design of a microgrid,

examine the process of mapping designs to accommodate available ...



MDT

Microgrid Design Toolkit Microgrids are organized collections of distributed energy resources (DER) and controls that can operate autonomously (independent of a bulk power grid) when necessary (or always) to provide electrical power. They support resiliency, security, efficiency, local control, and increased access to renewable resources. They can provide reliable power ...

latvia microgrids

latvia microgrids. latvia microgrids. Microgrid Technology: What Is It and How It Works? What Is A Microgrid And How Does It Work. Generally, a microgrid is a set of distributed energy systems (DES) operating dependently or independently of a larger utility grid, providing flexible local power to improve reliability while leveraging renewable



Microgrid System Design, Control, and Modeling ...

Microgrid System Design, Control, and Modeling Challenges and Solutions Scott Manson SEL ES Technology Director. Agenda o Example Projects o Challenges o Design Principles o Reconnection o Seamless Islanding Segment Simple ...



Feasibility Microgrid Design Study

Feasibility Microgrid Design Study The purpose of this project is to create a feasibility study proposal for the implementation of a Microgrid in Puente la Reina. Funded by Gobierno de Navarra through the program "Ayudas para mejora de la competitividad 2020". The expedient number of the project is 0011-1463-2020-000101.

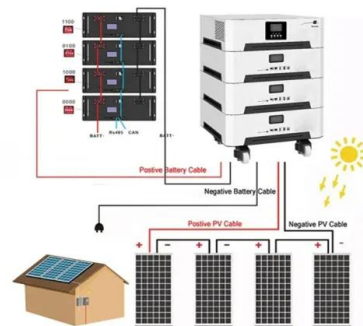

The Microgrid Design Toolkit

Sandia's Microgrid Design Toolkit (MDT) is a decision support software toolkit that aids designers in creating optimal microgrids. Microgrids are localized energy grids that provide flexibility through their ability to operate independently from the bulk power grid. Well-designed microgrids support resiliency, security, efficiency, local control, and increased access to renewable resources.

DESIGNING MICROGRIDS FOR EFFICIENCY AND RESILIENCY

A facility's energy demand is key to the design of a microgrid system. To ensure efficiency and resiliency, microgrids combine different components to meet a given demand, while optimizing ...



Sandia releases Microgrid Design Toolkit 1.4 to the public

Sandia has released the latest Microgrid Design Toolkit 1.4 software download to the public. MDT 1.4 expands on Sandia's existing MDT build, which serves as a decision support software for microgrid designers. Skip to main. Sandia National Laboratories. Search sandia.gov . Exceptional service in the national interest.

Optimized controllers design for incorporating renewable energy

2 ???· This paper presents the integration of renewable energy technologies in a DC microgrid, incorporating photovoltaic (PV) and battery systems connected to the grid. This ...



Fundamentals of Advanced Microgrid Design

Advanced Microgrid Design Overview. We consider a "microgrid" to be an integrated energy system consisting of loads and generation operating as a coherent unit. Microgrids may operate either in parallel with, or islanded from, ...

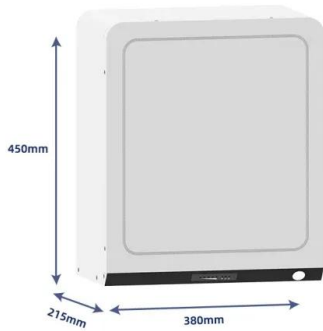

DCIDE

DCIDE is a microgrid design software that helps you create microgrids at the speed-of-thought with real-world components. It features a user-friendly design editor backed by a comprehensive product catalog. Try the design editor. Visit our product catalog. Videos. See it in action.



Contact Us

For catalog requests, pricing, or partnerships, please visit:
<https://bialydom.kolobrzeg.pl>