

## European Solar Energy Storage

# F1 racing energy storage device



## Overview

---

These innovations, derived from F1, promise to revolutionize both electric vehicles (EVs) and consumer energy storage. Racing in F1 is not just about speed—it's about efficiency, durability, and pushing technology to the limit. The lightweight construction, energy recovery systems, and...

These innovations, derived from F1, promise to revolutionize both electric vehicles (EVs) and consumer energy storage. Racing in F1 is not just about speed—it's about efficiency, durability, and pushing technology to the limit. The lightweight construction, energy recovery systems, and...

Batteries store electrical energy generated by the MGU-K kinetic energy recovery system and MGU-H heat energy recovery system. In F1 regulations, this is referred to as the Energy Store (ES), which covers the full system of battery cells and peripheral devices such as the inverter. Regulations...

Ferrari and Honda have each introduced upgraded energy stores within their Formula 1 power units in the second half of the 2021 season. The energy store is F1-speak for its lithium ion battery and, along with the control electronics housed within the energy store, it's a less-heralded part of the...

The battery element of the next-generation power units will be much more powerful, with the amount of electrical energy that can be generated rising nearly three-fold - from 120kW to 350kW. Fans have become accustomed to the most important technical developments on F1 cars being hidden from view in...

The Energy Recovery System (ERS) is a hybrid technology designed to capture and repurpose energy that would otherwise be wasted during a race. By working alongside the internal combustion engine (ICE), it boosts power unit performance and efficiency. The ERS consists of three key components, each...

F1 teams use advanced cooling systems, heat-conductive materials, and specialized coatings to dissipate this heat effectively, ensuring optimal performance throughout the race. Why Current Collectors Are Key for Heat Management: Material Properties: Current collectors, made from highly...

conductive.

Energy store or ES in F1 cars is a set of lithium-ion batteries that stores energy from the ERS and the powertrain. ES primarily delivers energy to the MGU-K and MGU-H. The battery also takes energy from MGU-K and MGU-H as well. MGU- K is motor generator unit – kinetic and MGU-H is motor generator. How does the energy recovery system work in F1?

Explore how the Energy Recovery System in F1 enhances power unit efficiency, boosts performance, and promotes sustainability. Formula 1 's Energy Recovery System (ERS) transforms wasted energy into usable power, adding 160 horsepower to a car's output while improving fuel efficiency by about 35%. The system combines two technologies:.

Which F1 power units have upgraded energy stores?

Ferrari and Honda have each introduced upgraded energy stores within their Formula 1 power units in the second half of the 2021 season. The energy store is F1-speak for its lithium ion battery and, along with the control electronics housed within the energy store, it's a less-heralded part of the complicated modern hybrid engines.

How important is storing and deploying energy in F1 cars?

Recovering energy is only half the equation - storing and deploying it effectively is just as important. F1 cars use high-capacity battery systems operating at 400 volts, with a storage capacity of 4-6 kWh. These energy limits play a pivotal role in race strategy.

How will F1's energy recovery system change in 2026?

FIA regulations limit energy recovery and deployment, pushing teams to optimize usage for competitive advantage. With upcoming 2026 changes, electrical output will increase to 350 kW, further advancing F1's hybrid technology. F1 Uncovered: How Do We Keep the ERS Cool?

What is the Energy Recovery System (ERS)?

.

How do F1 cars repurpose energy?

F1 cars are marvels of engineering, designed to reclaim and repurpose energy

that would otherwise go to waste. This energy recovery happens through advanced systems working together seamlessly during a race.

Will F1's battery technology be a mystery from the outside?

Fans have become accustomed to the most important technical developments on F1 cars being hidden from view in the ground-effect aerodynamics era when underbody improvements can make so much difference, but battery technology will be even more of a mystery from the outside.

## F1 racing energy storage device

---



### What racing car uses flywheel energy storage? , NenPower

1. Various racing vehicles have incorporated flywheel energy storage systems, including the Formula 1, FIA Formula E, and Le Mans prototypes. 2. These innovative systems ...

### Flywheel hybrid systems (KERS)

In a Formula One application the 21 speeds available (3 CFT KERS x 7 car gearbox speeds) mean that during a typical racing lap the efficiency will be around 64% round ...



### (PDF) Enhancing vehicular performance with flywheel energy storage

Abstract Flywheel Energy Storage Systems (FESS) are a pivotal innovation in vehicular technology, offering significant advancements in enhancing performance in vehicular ...

### Kinetic energy recovery system

Figure 1. A kinetic energy recovery system. [1]  
 Kinetic energy recovery systems (KERS) are systems used in Formula 1 vehicles (ex. a race

car) in order to recover kinetic energy for future use. It works by converting the ...



## F1 Kinetic Energy Recovery System (KERS)

A significant technical innovation introduced in Formula One racing is that of the Kinetic Energy Recovery Systems, or KERS. Formula One's image has always been one of being environmentally unfriendly, ...



## Enhancing vehicular performance with flywheel energy storage ...

The paper begins by discussing various energy recovery systems. It then focuses on different energy storage devices, with a detailed examination of flywheel energy ...



## Skeleton Technologies' Supercapacitors Power ...

The Energy Storage System is composed of 20 supercapacitors developed and supplied by Skeleton Technologies. These supercapacitors were specifically chosen for their unparalleled ability to ...



## F1 Engineering

F1 Engineering FORMULA 1 HYBRID POWER UNIT  
 In the development of our Formula 1 power unit, from concept to racing, we require deep expertise in both hardware and software across ...

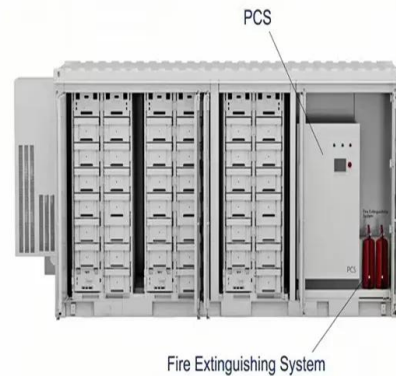

## How Does Battery Power Work in F1

In Formula One, battery power plays a crucial role in powering the cars. It is an essential component of the hybrid powertrain system that provides the energy needed to propel the car. How Battery ...

## **Evolution of the ESS Battery Unit and Control ...**

Batteries store electrical energy generated by the MGU-K kinetic energy recovery system and MGU-H heat energy recovery system. In F1 regulations, this is referred to as the Energy Store (ES), which covers the full system of ...



## **How Formula 1 is Powering Mercedes' Solid-State Battery**

...

One of F1's most influential innovations in battery development is the Energy Recovery System (ERS). This system allows race cars to harvest kinetic and thermal energy, ...



## Tackling KERS in Formula One

Systems used in Formula One No matter how the energy is stored in a KERS system, all Formula One teams have chosen for an electrical link between the car's drivetrain ...

### **12.8V 200Ah**



## Flywheel hybrid systems (KERS)

In a Formula One application the 21 speeds available (3 CFT KERS x 7 car gearbox speeds) mean that during a typical racing lap the efficiency will be around 64% round trip. In typical road car use the overall ...

## Electric race energy storage car

How does a hybrid energy system work in F1 Racing? This energy is converted into electrical energy and stored in batteries. When drivers press the boost button, the system releases this ...





## What is F1's energy store and why do recent upgrades matter?

The energy store is F1-speak for its lithium ion battery and, along with the control electronics housed within the energy store, it's a less-heralded part of the complicated modern ...

## What is F1's energy store and why do recent ...

The energy store is F1-speak for its lithium ion battery and, along with the control electronics housed within the energy store, it's a less-heralded part of the complicated modern hybrid engines. It supplies ...



18650 3.7V  
 Li-ion  
RECHARGEABLE BATTERY  
**2000mAh**



## How Formula 1 Car Sensors Create Data at Every Turn

Formula 1 is one of the most data-driven sports in history. And much of that data comes from hundreds of sensors built into every car.

## What is F1 Kers?

Key Takeaways: F1 Kers stands for Kinetic Energy Recovery System and is used in Formula One racing to improve power, efficiency, and handling. The system works by converting kinetic energy from braking and heat into ...



## How ERS Boosts F1 Power Unit Efficiency

The Energy Recovery System (ERS) is a game-changer in Formula One, designed to capture and reuse energy that would otherwise be lost. It pulls energy from two primary sources: the heat ...



## Energy Optimal Control for Formula One Race Car

Formula One (F1) is considered to be the forefront of innovation for the automotive and motorsport industry. One of the key provisions has been towards the inclusion ...

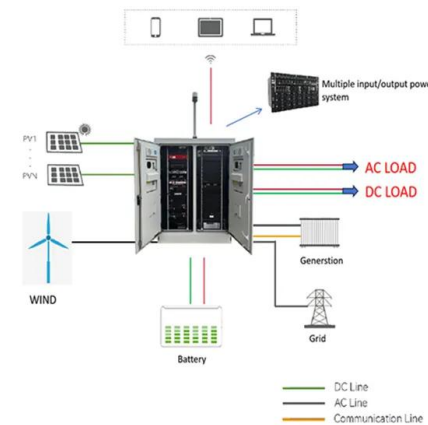

## F1 Racing Energy Storage Devices: Powering Speed and ...

Ever wondered how Formula 1 cars manage to hit 230 mph while sipping energy like a frugal espresso drinker? The secret sauce? Energy storage devices (ESDs). These high-tech ...

## F1's 10-year race towards ultimate energy efficiency

Two years ago, just four seasons into Formula 1's hybrid era, the sport's champion team, Mercedes, issued a statement that in a dynamometer test at its High ...



## What is F1's energy store and why do recent ...

The energy store is F1-speak for its lithium ion battery and, along with the control electronics housed within the energy store, it's a less-heralded part of the complicated modern hybrid engines.

## What is KERS? How It is used in Formula One?

What is KERS? The acronym KERS stands for Kinetic Energy Recovery System. The device recovers the kinetic energy that is present in the waste heat created by the ...



## F1's 10-year race towards ultimate energy efficiency

Two years ago, just four seasons into Formula 1's hybrid era, the sport's champion team, Mercedes, issued a statement that in a dynamometer test at its High Performance Powertrains factory in ...



## Kinetic Energy Recovery Systems in Formula 1

The initiative for Formula 1 teams to implement KERS into their cars was spearheaded by the president of the FIA, the governing body for Formula One racing. His incentive was to improve the public image of Formula 1's ...



## What is ERS in F1? (: formula 1 energy recovery system)

Introduction Formula 1 racing is known for its technical sophistication and the use of cutting-edge innovations. One of the technologies widely used in F1 racing is the Energy ...

## IndyCar goes hybrid-electric with energy recovery system

The NTT IndyCar Series ushers in a new era of electrified hybrid racing this weekend by introducing an ERS (energy recovery system). A collaborative effort between ...





## **Formula 1 batteries: The invisible development race essential to ...**

Battery technology has been an integral part of Formula 1's development race for a decade now, since the advent of the turbo-hybrid regulations, but the forthcoming 2026 rule ...

## **Contact Us**

---

For catalog requests, pricing, or partnerships, please visit:  
<https://bialydom.kolobrzeg.pl>